

Product Features

- Compliant with IEEE Std 802.3-2005
10G Ethernet 10GBase-LR/LW
- Electrical interface specifications per SFF-8431
- Management interface specifications per SFF-8431 and SFF-8472
- SFP+ MSA package with duplex LC connector
- Uncooled 1310nm DFB Laser
- Up to 10.3Gb/s bi-directional data links
- Single +3.3V power supply
- Class 1 laser safety certified
- Operating temperature Options
 - (Commercial) 0°C to +70°C
 - (Industrial) -40°C to +85°C
- Up to 10km on 9/125µm SMF
- RoHS Compliant



Applications

- 10G Ethernet 10GBASE-LR/LW
- 10G Fiber Channel 1200-SM-LL-L

Descriptions

LX4002CDR SFP+ transceivers, according to Enhanced 8.5 and 10 Gigabit Small Form Factor Pluggable “SFP+” Multi-Sourcing Agreement (MSA) SFF-8431 and SFF-8472, revision 10.4, are designed for 10G Ethernet serial optical data communication up to 10km on single mode fiber. They are compliant with IEEE Std 802.3-2005 10Gb Ethernet 10GBase-LR/LW and 10G Fiber Channel 1200-SM-LL-L.

LX4002C(I)DR offer commercial and industrial operating temperature options.

Ordering Information

Table 1. Ordering Information

| Part Number | Transmitter | Output Power | Receiver | Sensitivity | Reach | Temp | DDM | RoHS |
|-------------|-------------|----------------|----------|-------------|-------|-------------|-----------|-----------|
| LX4002CDR | 1310nm DFB | -8.2 ~ +0.5dBm | PIN | < -14.4dBm | 10km | 0 ~ 70 °C | Available | Compliant |
| LX4002IDR | 1310nm DFB | -8.2 ~ +0.5dBm | PIN | < -14.4dBm | 10km | -40 ~ 85 °C | Available | Compliant |

Pin Description

Table 2. Pin Description

| Pin | Name | Function/Description | Notes |
|-----|------------|--|-------|
| 1 | VeeT | Transmitter Ground | 1 |
| 2 | TX_Fault | Transmitter Fault (LVTTTL-O) - High indicates a fault condition | 2 |
| 3 | TX_Disable | Transmitter Disable (LVTTTL-I) – High or open disables the transmitter | 3 |
| 4 | SDA | Two wire serial interface Data Line (LVCMOS-I/O) (MOD-DEF2) | 4 |
| 5 | SCL | Two wire serial interface Clock Line (LVCMOS-I/O) (MOD-DEF1) | 4 |
| 6 | MOD_ABS | Module Absent (Output), connected to VeeT or VeeR in the module | 5 |
| 7 | RS0 | Rate Select 0 – Not used, Presents high input impedance | - |
| 8 | RX_LOS | Receiver Loss of Signal (LVTTTL-O) | 2 |
| 9 | RS1 | Rate Select 1 – Not used, Presents high input impedance | - |
| 10 | VeeR | Receiver Ground | 1 |
| 11 | VeeR | Receiver Ground | 1 |
| 12 | RD- | Inverse Received Data out (CML-O) | - |
| 13 | RD+ | Received Data out (CML-O) | - |
| 14 | VeeR | Receiver Ground | - |
| 15 | VccR | Receiver Power - +3.3V | - |
| 16 | VccT | Transmitter Power - +3.3 V | - |
| 17 | VeeT | Transmitter Ground | 1 |
| 18 | TD+ | Transmitter Data In (CML-I) | - |
| 19 | TD- | Inverse Transmitter Data In (CML-I) | - |
| 20 | VeeT | Transmitter Ground | 1 |

Notes:

1. The module signal grounds are isolated from the module case.
2. This is an open collector/drain output that on the host board requires a 4.7KΩ to 10KΩ pull-up resistor to VccHost.
3. This input is internally biased high with a 4.7KΩ to 10KΩ pull-up resistor to VccT.
4. Two-Wire Serial interface clock and data lines require an external pull-up resistor dependent on the capacitance load.
5. This is a ground return that on the host board requires a 4.7KΩ to 10KΩ pull-up resistor to VccHost.

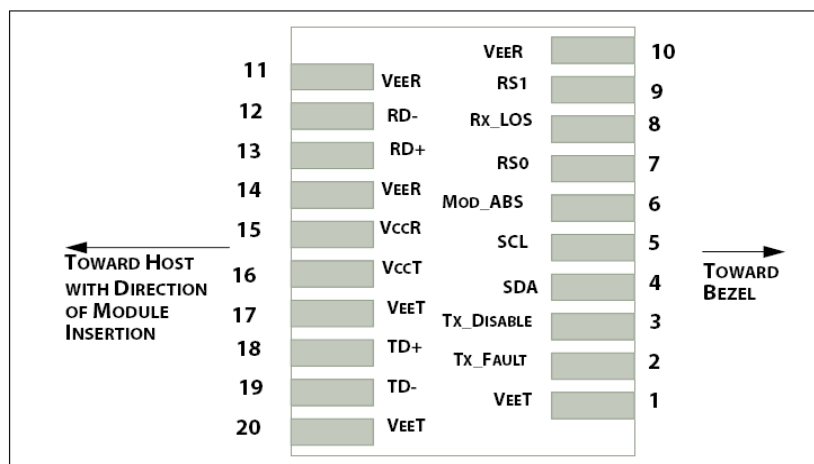

Figure 1. Host PCB SFP+ pad assignment top view

Absolute Maximum Ratings

Stresses in excess of the absolute maximum ratings can cause permanent damage to the device. These are absolute stress ratings only. Functional operation of the device is not implied at these or any other conditions in excess of those given in the operational sections of the data sheet. Exposure to absolute maximum ratings for extended periods can adversely affect device reliability.

Table 3. Absolute Maximum Ratings

| Parameter | Symbol | Minimum | Maximum | Unit |
|---------------------|-----------------|---------|---------|------|
| Storage Temperature | T _S | -40 | 85 | °C |
| Relative Humidity | RH | 5 | 95 | % |
| Supply Voltage | V _{CC} | -0.5 | 4.0 | V |

Recommended Operating Conditions

Table 4. Recommended Operating Conditions

| Parameter | Symbol | Min | Typ | Max | Unit | |
|-----------------------|-----------------|----------------|---------|-------|------|----|
| Operating Temperature | LX4002CDR | T _C | 0 | 25 | 70 | °C |
| | LX4002IDR | T _C | -40 | 25 | 85 | °C |
| Supply Voltage | V _{CC} | 3.135 | 3.3 | 3.465 | V | |
| Data Rate | - | - | 10.3125 | - | Gb/s | |

Transceiver Electrical Characteristics

Table 5. Transceiver Electrical Characteristics

| Parameter | Symbol | Minimum | Typical | Maximum | Unit | Notes | |
|----------------------------------|---------------------------------|-----------------|---------|---------|---------------------|-------|---|
| Module Supply Current | I _{CC} | - | - | 290 | mA | - | |
| Power Dissipation | P _D | - | - | 1000 | mW | - | |
| Transmitter | | | | | | | |
| Input Differential Impedance | Z _{IN} | - | 100 | - | Ω | - | |
| Differential Data Input Swing | V _{IN,P-P} | 180 | - | 700 | mV _{P-P} | - | |
| TX_FAULT | Transmitter Fault | V _{OH} | 2.0 | - | V _{CCHOST} | V | - |
| | Normal Operation | V _{OL} | 0 | - | 0.8 | V | - |
| TX_DISABLE | Transmitter Disable | V _{IH} | 2.0 | - | V _{CCHOST} | V | - |
| | Transmitter Enable | V _{IL} | 0 | - | 0.8 | V | - |
| Receiver | | | | | | | |
| Output Differential Impedance | Z _O | - | 100 | - | Ω | - | |
| Differential Data Output Swing | V _{OUT,P-P} | 300 | - | 850 | mV _{P-P} | 1 | |
| Data Output Rise Time, Fall Time | t _r , t _f | 28 | - | - | ps | 2 | |

| | | | | | | | |
|--------|----------------------|----------|-----|---|--------------|---|---|
| RX_LOS | Loss of signal (LOS) | V_{OH} | 2.0 | - | V_{CCHOST} | V | 3 |
| | Normal Operation | V_{OL} | 0 | - | 0.8 | V | 3 |

Notes:

1. Internally AC coupled, but requires a external 100Ω differential load termination.
2. 20 – 80 %.
3. LOS is an open collector output. Should be pulled up with 4.7kΩ on the host board.

Transmitter Optical Characteristics

Table 6. Transmitter Optical Characteristics

| Parameter | Symbol | Minimum | Typical | Maximum | Unit | Notes |
|------------------------------------|---|---------|---------|---------|------|-------|
| Launch Optical Power | P_o | -8.2 | - | +0.5 | dBm | 1 |
| Center Wavelength Range | λ_c | 1260 | 1310 | 1355 | nm | - |
| Extinction Ratio | EX | 3.5 | - | - | dB | 2 |
| Optical Modulation Amplitude | OMA | -5.2 | - | - | dBm | |
| Spectral Width (-20dB) | $\Delta\lambda$ | - | - | 1 | nm | - |
| Side Mode Suppression Ratio | SMSR | 30 | - | - | dB | - |
| Transmitter and Dispersion Penalty | TDP | - | - | 3.2 | dB | - |
| Optical Return Loss Tolerance | ORLT | - | - | 12 | dB | - |
| Pout @TX-Disable Asserted | P_{off} | - | - | -30 | dBm | 1 |
| Eye Diagram | IEEE Std 802.3-2005 10Gb Ethernet 10GBASE-LR compatible | | | | | |

Notes:

1. The optical power is launched into 9/125μm SMF.
2. Measured with a PRBS 2³¹-1 test pattern @10.3125Gbps.

Receiver Optical Characteristics

Table 7. Receiver Optical Characteristics

| Parameter | Symbol | Minimum | Typical | Maximum | Unit | Notes |
|------------------------------------|-------------|---------|---------|---------|------|-------|
| Center Wavelength | λ_c | 1260 | 1310 | 1355 | nm | - |
| Receiver Sensitivity (P_{avg}) | S | - | - | -14.4 | dBm | 1 |
| Receiver Sensitivity (OMA) | S_{OMA} | - | - | -12.6 | dBm | 1 |
| Receiver Overload (P_{avg}) | P_{OL} | 0.5 | - | - | dBm | 1 |
| Stressed Sensitivity (OMA) | - | - | - | -10.3 | dBm | 2 |
| Optical Return Loss | ORL | 12 | - | - | dB | - |
| LOS De-Assert | LOS_D | - | - | -17 | dBm | - |
| LOS Assert | LOS_A | -30 | - | - | dBm | - |
| LOS Hysteresis | - | 0.5 | - | - | dB | - |

Notes:

1. Measured with PRBS 2³¹-1 test pattern, 10.3125Gb/s, BER<10⁻¹².
2. Comply with IEEE 802.3-2005.

Recommended Host Board Power Supply Filter Network

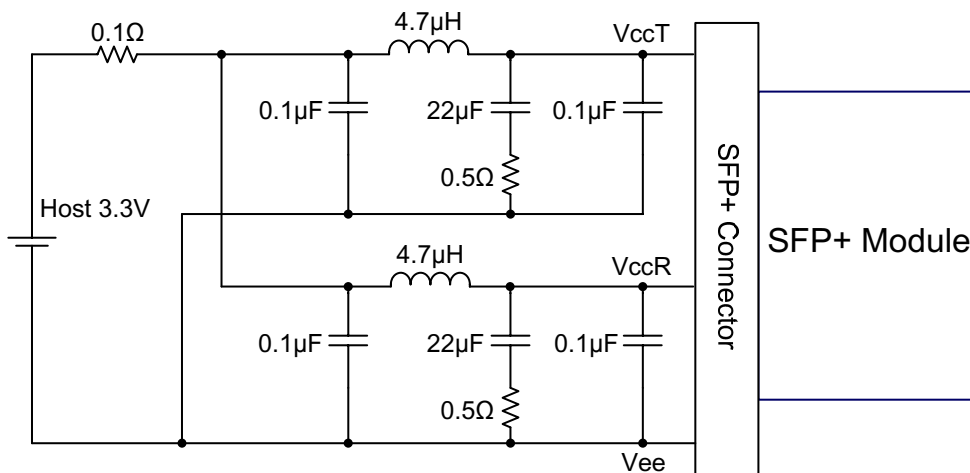

Figure 2. Recommended Host Board Power Supply Filter Network

Recommended Application Interface Block Diagram

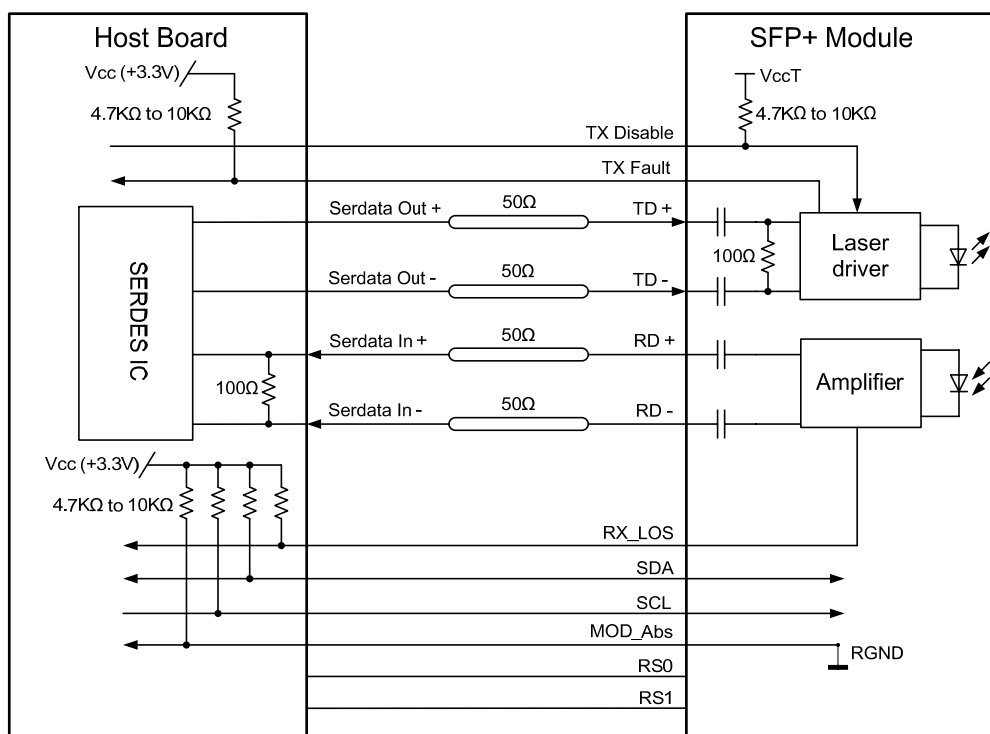

Figure 4. Recommended Application Interface Block Diagram

Mechanical specifications

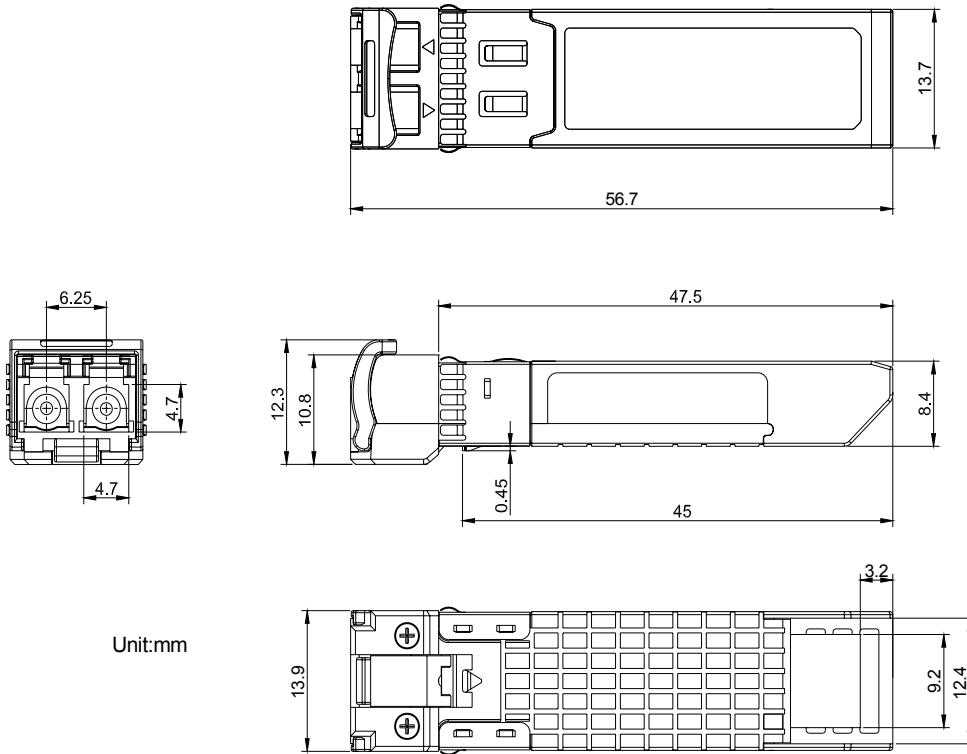

Figure 5. Outline Drawing

PCB layout recommendation

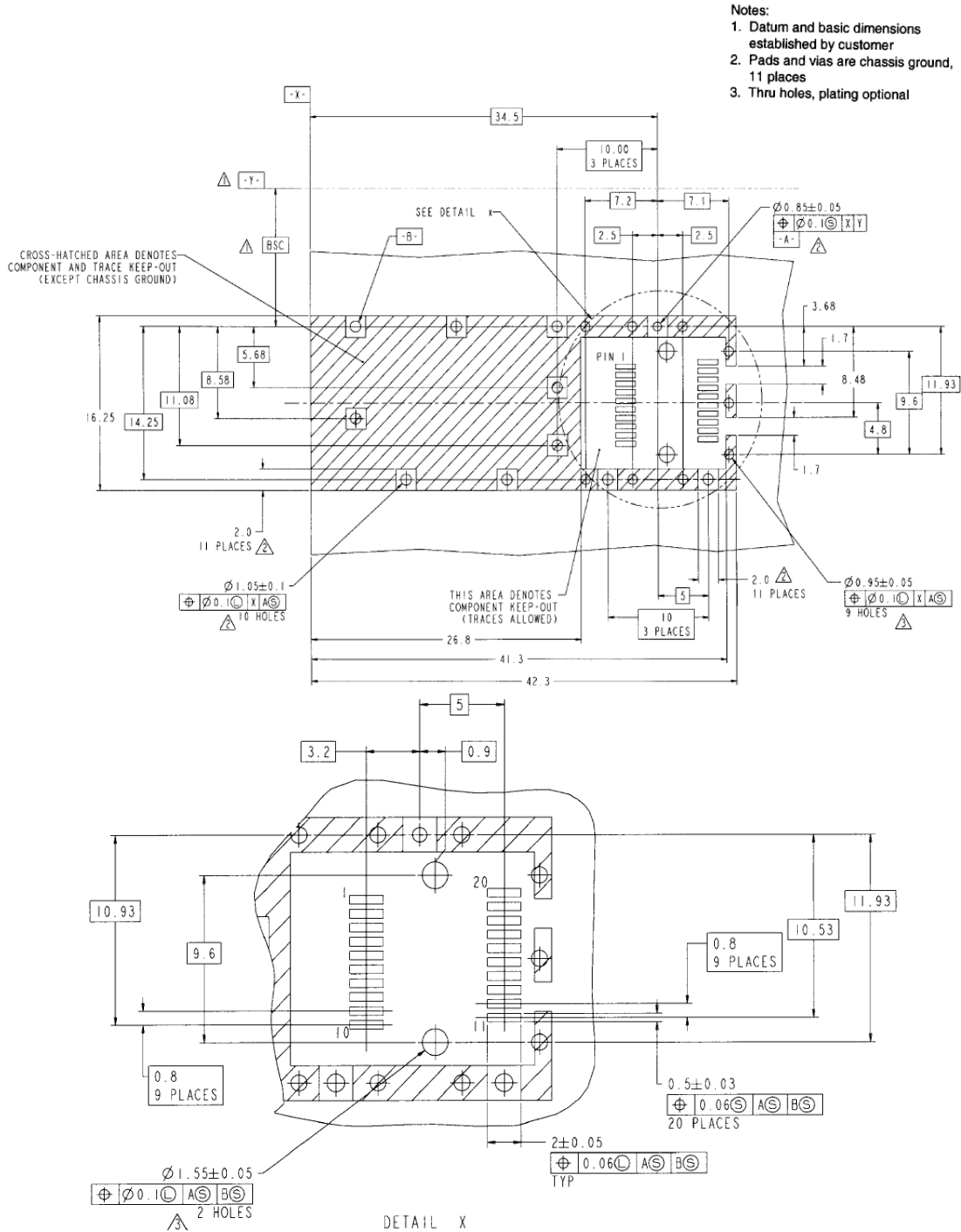

Figure 6. PCB layout recommendation

For More Information

Linktel Technologies Co., Ltd

sales@linkteltech.com

<http://www.linkteltech.com>

Linktel China

No. 4, Bldg. B5, Hang Yu, Wuhan University Science Park

East Lake Hi-tech Development Zone, Wuhan, 430223, China

Tel: +86 27-87929302

Linktel USA

3391 Ingersoll Ct., San Jose, CA 95148

Tel: +1-408-2613988