



SN-T5H-P-F

Body Temperature Measurement Camera
with Integrated Blackbody



Key Features

- Uncooled VOx Micro bolometer with 400×300 resolution
- One IP address two channels
- Camera and blackbody integrated design
- Support temperature screening
- NETD $\leq 40\text{mK}$
- Thermal: 8mm Fixed lens, Visible: 2.7~12mm motorized lens
- Accuracy $\pm 0.3^{\circ}\text{C}$
- 17 color control
- Support 1/1 audio input/output and 2/2 alarm input/output

Specification

Thermal Camera	
Detector Type	Uncooled IRFPA Microbolometer
Effective Pixels	400(H) x300(V)
Pixel Size	17um
Thermal Sensitivity (NETD)	≤40mK @F1.0, 300K
Spectral Range	8~14um
Image Setting	Polarity LUT/ DVE/ Mirror/ FCC/ /3D DNR Brightness/Contrast/ ROI
Color Palettes	Black-Hot/White-Hot/Rainbow/Ironbow up to 17 modes
Thermal Lens	
Lens Type	Fixed
Focus Control	Manual Focus
Focal Length	8mm
F No.	F1.0
Angle of View	H: 46°, V: 35°
Visible Camera	
Image Sensor	1/2.8" Sony CMOS
Effective Resolution	1920(H)x1080(V)
Shutter Speed	1/5 ~ 1/20,000s
Wide Dynamic Range	True WDR 120dB
Min. Illumination	Color: 0.1Lux @(F1.2, AGC ON) B/W: 0.01Lux @(F1.2, AGC ON)
S/N Ratio	More than 55dB
Focal Length	2.7 ~ 12mm
Max Aperture	F1.6~ F2.9
Angle of View	H: 89° ~ 33°, V: 48° ~ 18°
Focus Control	Motorized
Video and Audio	
Frame Rate	Main Stream: Visible: 1920x1080/1280x720 @25/30fps Thermal: D1 @25/30fps Sub Stream: Visible: D1/VGA/640x360/CIF/QVGA @25/30fps Thermal: CIF @25/30fps
Bit Rate Control	CBR/VBR
Bit Rate	Main Stream: Thermal: 100Kbps~6Mbps, Visible: 100Kbps~12Mbps Sub Stream: Thermal: 10Kbps~1.5Mbps, Visible: 10Kbps~6Mbps
Region of Interest	Off / On (8 Zone, Rectangle)
Digital Zoom	16x
Mirror	Support
Defog	Support
Motion Detection	Support
Privacy Masking	Off / On (4 Area, Rectangle)
DVE Image Enhance	Support
Audio Compression	G.711, RAW_PCM

Intelligence	
Face Detection	Support face detection and capture
Temperature Detection	
Temperature Detection	Body temperature monitoring
Temperature Alarm	Over temperature alarm
Accuracy	± 0.3 °C (Emission rate, distance, ambient temperature, etc.) Environment temperature: 0°C~35°C(32°F~95°F) Detection Distance: 3~5m (4m recommended) Working Environment: Avoid the interference of wind, sunshine, high temperature and reflective objects, indoor is recommended
Response Time	≤30ms
Network	
Ethernet	RJ-45 (10/100Base-T)
Protocols	IPv4/IPv6 ,HTTP,RTSP/RTP/RTCP, TCP/UDP, DHCP, DNS, PPPoE, SMTP, SIP ,802.1x
Interoperability	ONVIF, CGI, SDK
Max. User Access	10 Users
Edge Storage	Local PC for instant recording
Web Viewer	<IE11, Chrome, Firefox
Web Language	English, Chinese, Polish, Italian, Portuguese, Spanish. Russian, French, Czech, Hungarian
Interface	
Ethernet	1 Ethernet (10/100 Base-T) RJ-45 Connector
Audio Interface	1ch Audio In,1ch Audio Out
Alarm	2ch Alarm In,2ch Alarm Out
RS485	Support
Reset Button	Support (Built-in)
Power Interface	DC12V input interface for blackbody
General	
Power Supply	DC12V/POE (IEEE 802.3af)
Power Consumption	Max 18W
Operating Temperature	0°C~35°C (32°F~95°F)
Storage Conditions	0~ 90% RH
Certifications	CE /FCC
Ingress Protection	IP54
Casing	Metal + Plastic
Dimensions	380x244x142 mm (14.96x9.6x5.59 inch)
Net Weight	2.26 kg (4.98 lb)

Dimensions (mm)

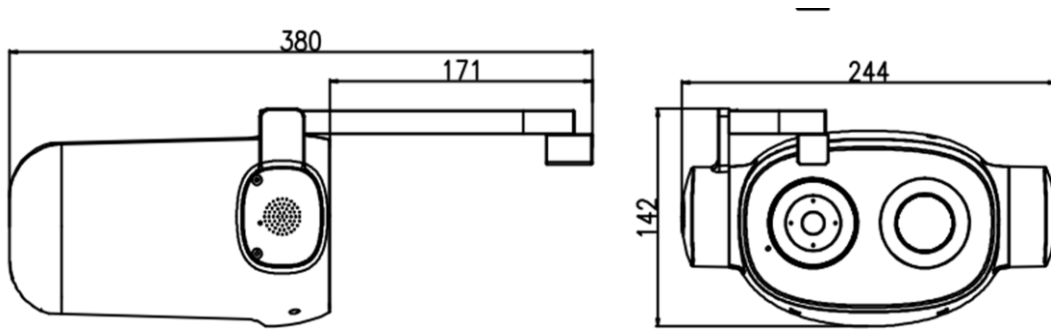

Accessories

Optional:



SN-BK346
Wall bracket



SN-BK350
Ceiling Bracket



SN-BK360
Tripod

Disclaimer:

Sunell Body Temperature Measurement System is not a medical device and is not designed for diagnosis, prevention, or treatment of any disease or condition.

The solution is a screening tool that businesses can use to identify individuals with elevated skin temperature compared to a customizable reference temperature on entering their premises.