

TC620 & TC840R1

Thermal IP cameras in aluminium housing

Installation Manual



TCH
GROUP

**SECURITY
SOLUTIONS**

Note: To ensure proper operation, please read this manual thoroughly before using the product and retain the information for future reference.

Copyright © 2017 Siqua B.V.

All rights reserved.

TC620/TC840R1 MNVCHTV32_1511_EN
Installation Manual v3 (153103-3)
AIT55

Nothing from this publication may be copied, translated, reproduced, and/or published by means of printing, photocopying, or by any other means without the prior written permission of Siqua.

Siqua reserves the right to modify specifications stated in this manual.

Brand names

Any brand names mentioned in this manual are registered trademarks of their respective owners.

Liability

Siqua accepts no liability for claims from third parties arising from improper use other than that stated in this manual.

Although considerable care has been taken to ensure a correct and suitably comprehensive description of all relevant product components, this manual may nonetheless contain errors and inaccuracies. We invite you to offer your suggestions and comments by email via t.writing@tkhsecurity.com. Your feedback will help us to further improve our documentation.

How to contact us

If you have any comments or queries concerning any aspect related to the product, do not hesitate to contact:

Siqua B.V.
Zuidelijk Halfroond 4
2801 DD Gouda
The Netherlands

General : +31 182 592 333
Fax : +31 182 592 123
E-mail : sales.nl@tkhsecurity.com
WWW : <http://www.tkhsecurity.com>

Contents

1	About this manual	4
1.1	Typographical conventions	4
1.2	Copyright and trademarks	4
2	Safety rules	5
3	Identification	7
3.1	Product description and type designation	7
3.2	Product markings	7
4	Preparing the product for use	8
4.1	Unpacking	8
4.2	Contents	8
4.3	Disposing of packaging material	8
4.4	Preparatory work before installation	9
4.4.1	<i>Attaching the bracket</i>	9
5	Installation	10
5.1	How to open the housing	10
5.2	How to install the camera	10
5.3	Board description	11
5.4	Connection of the power supply line	12
5.4.1	<i>Type of cable</i>	12
5.5	Installation of the version with double filter for air renewal	12
6	Accessories	14
6.1	Heater	14
6.1.1	<i>Heater installation</i>	14
6.2	Camera power supply	15
6.2.1	<i>Camera power supply installation</i>	15
6.3	Blower	16
6.3.1	<i>Blower installation</i>	16
7	Cleaning	18
7.1	Window and plastic cover cleaning	18
8	Disposal of waste materials	19
9	Technical data	20
9.1	General	20
9.2	Mechanical	20
9.3	Housing window	20
9.4	Digital I/O	21
9.5	Electrical	21
9.6	Environment	22
9.7	Certifications	22
10	Technical drawings	23
	Index	24

1 About this manual

Before installing and using this unit, read this manual carefully. Be sure to keep it handy for later reference.

In This Chapter

1.1 Typographical conventions.....	4
1.2 Copyright and trademarks.....	4

1.1 Typographical conventions



DANGER!
High level hazard.
Risk of electric shock. Disconnect the power supply before proceeding with any operation, unless indicated otherwise.



CAUTION!
Medium level hazard.
This operation is very important for the system to function properly. Please read the procedure described very carefully and carry it out as instructed.



INFO
Description of system specifications.
We recommend reading this part carefully in order to understand the subsequent stages.

1.2 Copyright and trademarks

The quoted names of products or companies are trademarks or registered trademarks.

2 Safety rules



CAUTION! The device must be installed only and exclusively by skilled technical personnel.



CAUTION! The electrical system to which the unit is connected must be equipped with an automatic bipolar circuit breaker. The circuit breaker for main supply voltage phase units must have a level of intervention of 20 A max. The circuit breaker for low voltage units must have a level of intervention of 6 A max. This circuit breaker must be of the Listed type. The minimum distance between the contacts must be 3 mm (0.1 in). The circuit breaker must be provided with protection against the fault current towards the ground (differential) and the overcurrent (magnetothermal).

- The manufacturer declines all responsibility for any damage caused by an improper use of the appliances mentioned in this manual. Furthermore, the manufacturer reserves the right to modify its contents without any prior notice. The documentation contained in this manual has been collected with great care. The manufacturer, however, cannot take any liability for its use. The same thing can be said for any person or company involved in the creation and production of this manual.
- Before starting any operation, make sure the power supply is disconnected.
- Do not use cables that seem worn or old.
- Never, under any circumstances, make any changes or connections that are not shown in this handbook. Improper use of the appliance can cause serious hazards, risking the safety of personnel and of the installation.
- Use only original spare parts. Non-original spare parts could cause fire, electrical discharge or other hazards.
- Before proceeding with the installation, check the supplied material to make sure it corresponds to the order specification by examining the identification labels (see "Product markings" on page 7).
- This device was designed to be permanently installed on a building or on a suitable structure. The device must be installed permanently before any operation. The altitude of operation is up to 2000 metres.
- When installing the device, comply with all the national standards.
- Installation category (also called Overvoltage Category) specifies the level of mains voltage surges that the equipment will be subjected to. The category depends upon the location of the equipment, and on any external surge protection provided. Equipment in an industrial environment, directly connected to major feeders/short branch circuits, is subjected to Installation Category III. If this is the case, a reduction to Installation Category II is required. This can be achieved by use of an insulating transformer with an earthed screen between primary and secondary, or by fitting listed Surge Protective Devices (SPDs) from live to neutral and from neutral to earth. Listed SPDs shall be designed for repeated limiting of transient voltage surges, suitable rated for operating voltage and designated as follows: Type 2 (Permanently connected SPDs intended for installation on the load side of the service equipment overcurrent device); Nominal Discharge Current (In) 20 kA min. For example: FERRAZ SHAWMUT, STT2240SPG-CN, STT2BL240SPG-CN rated 120 Vac / 240 Vac, (In=20 kA). Maximum distance between installation and reduction is 5 m.
- Any device which could be installed inside the product must comply with the current safety standards.
- If the installation is NEMA TYPE 4X, the installer must replace the cable glands of the product with NEMA TYPE 4X cable glands.

- For all connections, use cables that are able to withstand temperatures of at least 75 °C (167 °F).
- The product is designed to house only cameras that are properly certified (7 W max).
- A disconnecting device, readily and easily accessible, must be incorporated in the electrical system of the building for rapid intervention.
- To connect the power supply line use the appropriate junction-box (UPTJBUL). For further information, refer to the product use and installation manual.
- Use Listed copper tube crimping lugs for the connection of the network conductors to the terminals. The copper tube crimping lugs must be suitable for the type of installation (from -20 °C (-4 °F) to +80 °C (+176 °F) min., V-0). Copper tube crimping lugs examples: RP, BP or YP (Cembre).

3 Identification

In This Chapter

3.1 Product description and type designation.....	7
3.2 Product markings.....	7

3.1 Product description and type designation

This housing has been designed to fit thermal cameras with compact lenses for vision even in total darkness.

It is possible to use it for a wide range of day/night surveillance systems, such as: monitoring and rescue in the event of a fire, public safety, along with airport, industrial and environmental surveillance.

The frontal opening system allows an easy access to the camera and all internal connections.

A wide range of accessories for mounting the equipment is available, thereby satisfying all installation needs.

3.2 Product markings

See the label attached to the product.

4 Preparing the product for use



Any change that is not expressly approved by the manufacturer will invalidate the guarantee.

In This Chapter

4.1 Unpacking.....	8
4.2 Contents.....	8
4.3 Disposing of packaging material.....	8
4.4 Preparatory work before installation.....	9

4.1 Unpacking

When the product is delivered, make sure that the package is intact and that there are no signs that it has been dropped or scratched.

If there are obvious signs of damage, contact the supplier immediately.

Keep the packaging in case you need to send the product for repairs.

4.2 Contents

Check the contents to make sure they correspond with the list of materials as below:

- Housing
- Housing equipment:
 - Allen wrench
 - Spacers
 - Cable glands gaskets
 - Cable glands (x3)
 - Bolts and screws
 - Screws for camera
- Instructions manual
- Desiccant bag

4.3 Disposing of packaging material

The packaging material can all be recycled. The installer technician will be responsible for separating the material for disposal, and in any case for compliance with the legislation in force where the device is to be used.

When returning a faulty product we recommend using the original packaging for shipping.

4.4 Preparatory work before installation

4.4.1 Attaching the bracket



The product must be fastened with suitable equipment. The fastening means must guarantee the mechanical seal when a force equal to at least four times the weight of the device is applied.

5 Installation

In This Chapter

5.1 How to open the housing.....	10
5.2 How to install the camera.....	10
5.3 Board description.....	11
5.4 Connection of the power supply line.....	12
5.5 Installation of the version with double filter for air renewal.....	12

5.1 How to open the housing

Loosen the two screws on the side, turn the cover and the upper half of the body about the opening hinge axis.

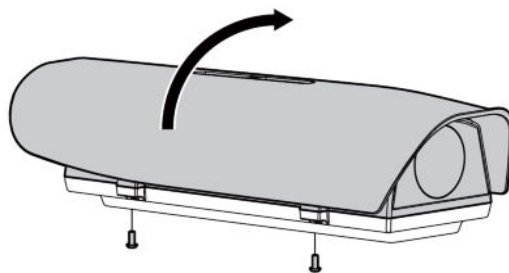

Fig. 1



At the end of installation and cabling operations close the housing.

5.2 How to install the camera



Power supply can be provided by the board supplied with the product. Make sure the voltage values are appropriate.

Open the housing as described (see "How to open the housing" on page 10).

Partially loosening the fastening screws (01).

Remove the internal slide (02) by sliding it until the holes coincide with the slide fastening screws.

Fasten the camera with the 1/4" screw (03). To position the camera and lens correctly, if necessary, use the supplied spacers. (04).

Reposition the internal slide and tighten the screws that were loosened previously.

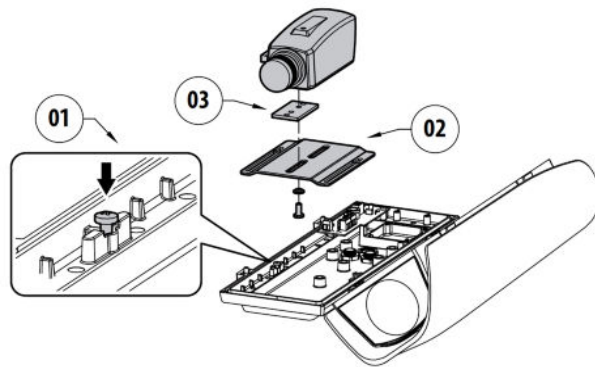

Fig. 2

Remove the conductors protective sheathing and connect them to terminal J5 (see "Board description" on page 11).

The camera's power supply cable conductors must be tied up with a cable tie next to the terminal. Keep the signalling and power supply cables separated from each other.

5.3 Board description



Connect the safety earth to the relative terminal of the J1 connector.



The board may appear different to the one illustrated.



Depending on the product version, the board may not be equipped with all functions.

BOARD DESCRIPTION			
Connector	Function	Connector	Function
J1	Board power supply (V_{IN}) ¹	J5	Camera power supply (V_{OUT}) ⁴
J2	Auxiliary output (V_{OUT}) ²	J7	Power supply connector/jumper ⁵
J3	Heater power supply (V_{OUT})	J8	Fan power supply (V_{OUT})
J4	Tamper switch contacts ³	SW1	Tamper switch ³

Tab. 1

¹From 100 Vac - 240 Vac, 24 Vac or 12 Vdc.

²Same voltage applied to power supply terminal of the board (J1).

³Optional.

⁴Different alternatives are available depending on the version. $V_{OUT} = 12$ Vdc or $V_{OUT} = 24$ Vac, in relation to the type of power supply installed (see "Camera power supply installation" on page 15). $V_{OUT} = V_{IN}$, only for housings powered in 12 Vdc or 24 Vac, with jumper inserted (J7).

⁵For power supply in 12 Vdc or 24 Vac (see "Camera power supply installation" on page 15).

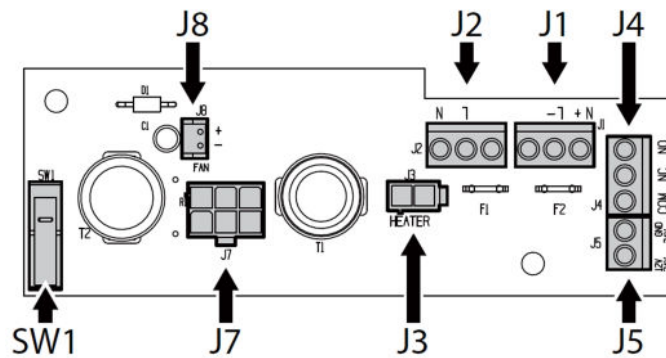

Fig. 3

5.4 Connection of the power supply line



Earth cable should be about 10 mm longer than the other two, so that it will not be disconnected accidentally if pulled.

Insert the cables for the connection to the power supply line inside the housing through the cable glands. The cable glands are suitable for conductors with diameters of between 5 mm and 10 mm. The section of the cable inside the housing must be sufficiently long to allow connection. Suitably lock the cable glands.

Remove the conductors protective sheathing and connect them to terminal J1 (see "Board description" on page 11).

5.4.1 Type of cable

The cable used for the connection to the power supply line must be suitable for the intended use. Comply with the current national standards on electrical installations.

5.5 Installation of the version with double filter for air renewal



During installation pay attention to the orientation of the air inlet filter fins.

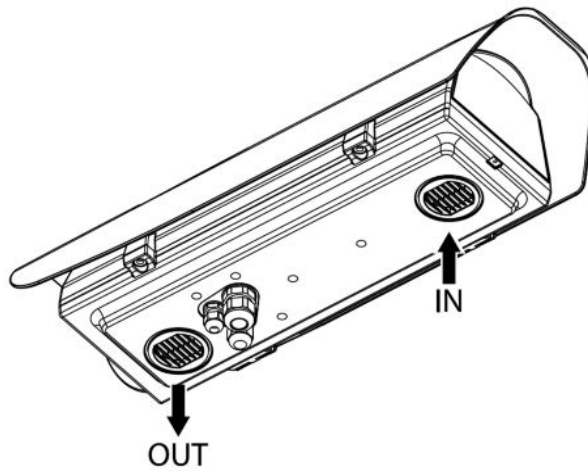

Fig. 4

Depending on the angle of inclination of the housing, the orientation of the filter fins must prevent water penetrating in case of rain.

To guarantee the weatherproofness, install the housing on the support following the inclination limits as shown in the picture.

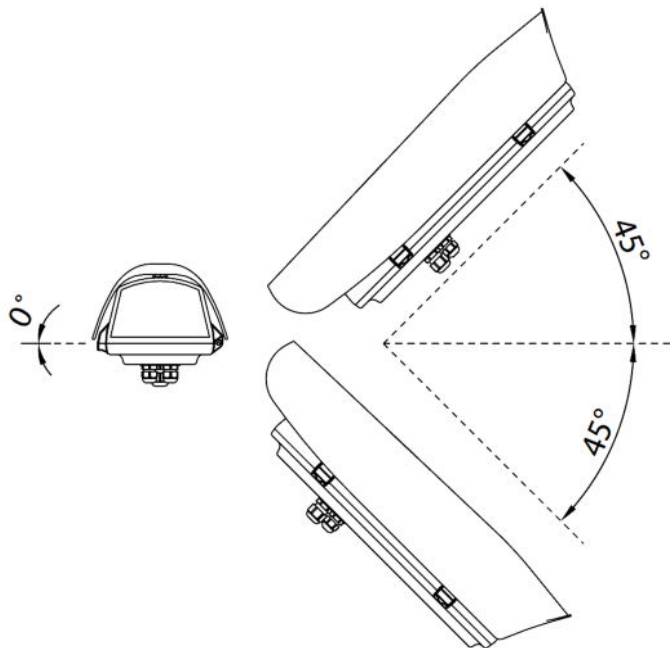

Fig. 5 Maximum tilt of the transversal axis: 0°. Maximum tilt of the longitudinal axis: $\pm 45^\circ$.

6 Accessories



For further details on configuration and use, refer to the user manual.

In This Chapter

6.1 Heater.....	14
6.2 Camera power supply.....	15
6.3 Blower.....	16

6.1 Heater

6.1.1 Heater installation

Open the housing as described (see "How to open the housing" on page 10).

Fix the heater kit to the prearranged points on the body of the housing.

The prewired heating element (01) should be positioned between the two dissipators (02) before attachment to ensure contact and hence guarantee correct heat transmission.

Pass the heating wiring under the fixing slide of the camera.

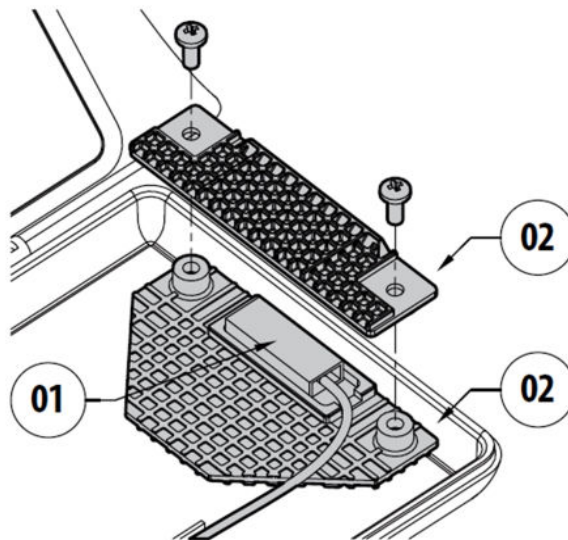

Fig. 6

At the end of the installation, connect the wiring to the terminal (power supply connector) (see "Board description" on page 11).

Reposition the internal slide and tighten the screws that were loosened previously.

6.2 Camera power supply

6.2.1 Camera power supply installation



Not usable in housings with wiper device installed.



**Pay attention to the voltage value used when the circuit is powered.
Depending on requirements use the correct power supply kit.**

There are two types of camera power supply depending on requirements.

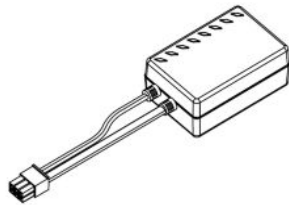

Fig. 7 V_{IN} from 100 Vac - 240 Vac, V_{OUT} 12 Vdc

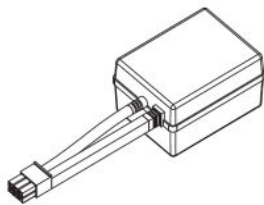

Fig. 8 V_{IN} 230 Vac, V_{OUT} 24 Vac

Open the housing as described (see "How to open the housing" on page 10).

Fix the support bracket (02) using the screw (01).

Place the power supply (03) on the support bracket.

Secure it all with the screws (04) and the corner fixing bracket.

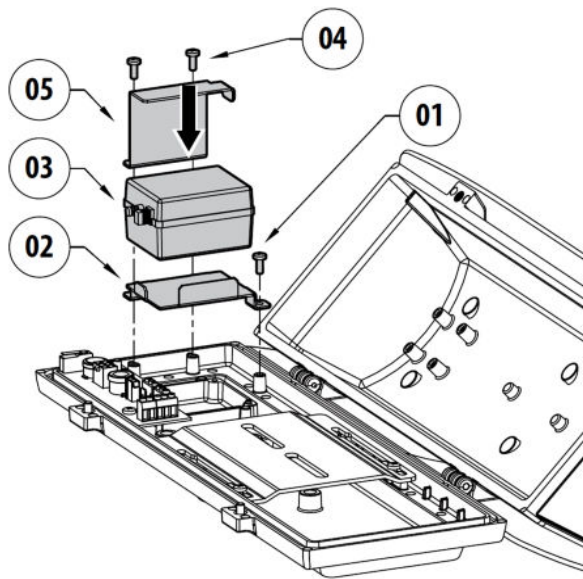

Fig. 9

Plug the multipolar female connector into the corresponding male connector J7 (see "Board description" on page 11).

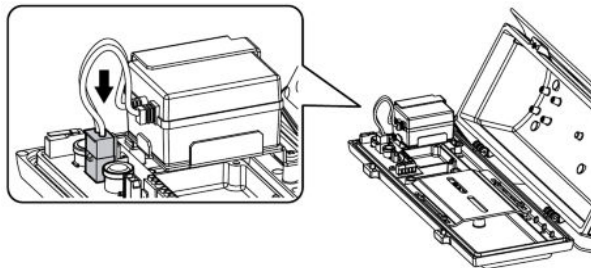

Fig. 10

6.3 Blower

6.3.1 Blower installation



Not usable in versions with double filter for air renewal and wiper.



Pay attention to the voltage value used when the circuit is powered. Depending on requirements use the correct power supply kit.



The blower kit should be assembled according to the instructions to ensure a correct air circulation inside the housing.

Open the housing as described (see "How to open the housing" on page 10).
Fix the blower using the corner bracket and screws.

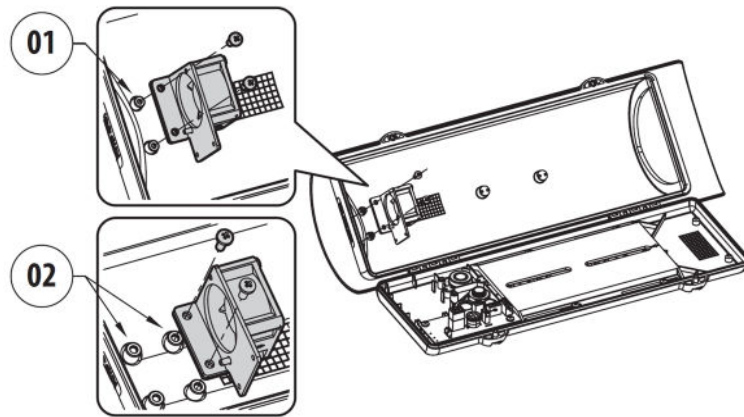

Fig. 11

Plug the multipolar female connector into the corresponding male connector J8 (see "Board description" on page 11).

7 Cleaning

In This Chapter

7.1 Window and plastic cover cleaning..... 18

7.1 Window and plastic cover cleaning



Avoid ethyl alcohol, solvents, hydrogenated hydrocarbide, strong acid and alkali. Such products may irreparably damage the surface.

We recommend using a soft cloth with neutral soaps diluted with water or specific products to clean eyeglasses lenses.

8 Disposal of waste materials



This symbol and recycle system apply to EU countries only. They are not applicable to countries in other areas of the world.

Your product is designed and manufactured with high quality materials and components which can be recycled and reused.

This symbol means that electrical and electronic equipment, at their end-of-life, should be disposed of separately from your household waste.

Please dispose of this equipment at your local Community waste collection or Recycling centre.

In the European Union there are separate collection systems for used electrical and electronic products.

9 Technical data

In This Chapter

9.1 General.....	20
9.2 Mechanical.....	20
9.3 Housing window.....	20
9.4 Digital I/O.....	21
9.5 Electrical.....	21
9.6 Environment.....	22
9.7 Certifications.....	22

9.1 General

Constructed from aluminium

Sunshield in ABS

Epoxy polyester powder painting, RAL9002 colour

Stainless steel external screws

9.2 Mechanical

Cable glands: 3x M16

Dimensions (WxHxL): 176x160x514 mm (6.9x6.3x20.2 in)

Unit weight: 4 kg (8.8 lb)

9.3 Housing window

Germanium window

- Dimensions (Ø): 55 mm (2.1 in)
- Thick: 2 mm (0.07 in)
- External scratch-resistant treatment: Hard Carbon Coating (DLC)
- Internal antireflection treatment
- Spectral range: 7.5~14 µm
- Medium transmittance (7.5~11.5 µm): 94%
- Medium transmittance (11.5~14 µm): 90%

Transmittance spectrum

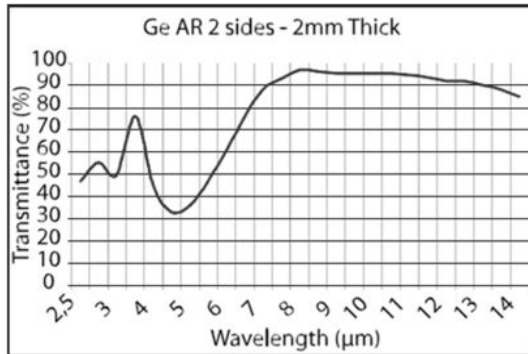

Fig. 12

9.4 Digital I/O

CC input: : Low level <1V; High level >2.2V or open, Internal pull-up 3.3 V, 2.2 kΩ; max input voltage: 9 Vdc.

CC output: Open collector type, max 30 Vdc; 2 A

9.5 Electrical

Power supply / Current consumption (empty version):

- 12 Vdc ~ 24 Vdc, 1 A max
- 12 Vac ~ 24 Vac, 1 A max, 50/60 Hz
- 120 Vac ~ 230 Vac, 400 mA max, 50/60 Hz

Power supply / Current consumption (version with heater, Ton 15 °C ± 3 °C (59 °F ± 5 °F), Toff 22 °C ± 3 °C (77 °F ± 5 °F)):

- 12 Vdc ~ 24 Vdc, 3 A max
- 12 Vac ~ 24 Vac, 3 A max, 50/60 Hz
- 120 Vac ~ 230 Vac, 400 mA max, 50/60 Hz

Camera power supply:

- V_{IN} 100 Vac ~ 240 Vac, 50/60 Hz
 V_{OUT} 12 Vdc, 1 A
- V_{IN} 230 Vac, 50/60 Hz
 V_{OUT} 24 Vac, 400 mA, 50/60 Hz

9.6 Environment

Indoor/Outdoor

Operating temperature (with heater): -20 °C (-4 °F) ~ +75 °C (167 °F)

Altitude of operation: Up to 2000 m

9.7 Certifications

Electrical safety (CE): EN60950-1

Electromagnetic compatibility (CE): EN50130-4, EN61000-6-3

IP protection degree: EN60529

- IP66/IP67 (with cable glands)
- IP66/IP67 (with bracket with internal cable channel, with sealing rings)
- IP55 (with bracket with internal cable channel)
- IP44 (with double filter for air renewal)

EAC certification

10 Technical drawings



The dimensions of the drawings are in millimetres.

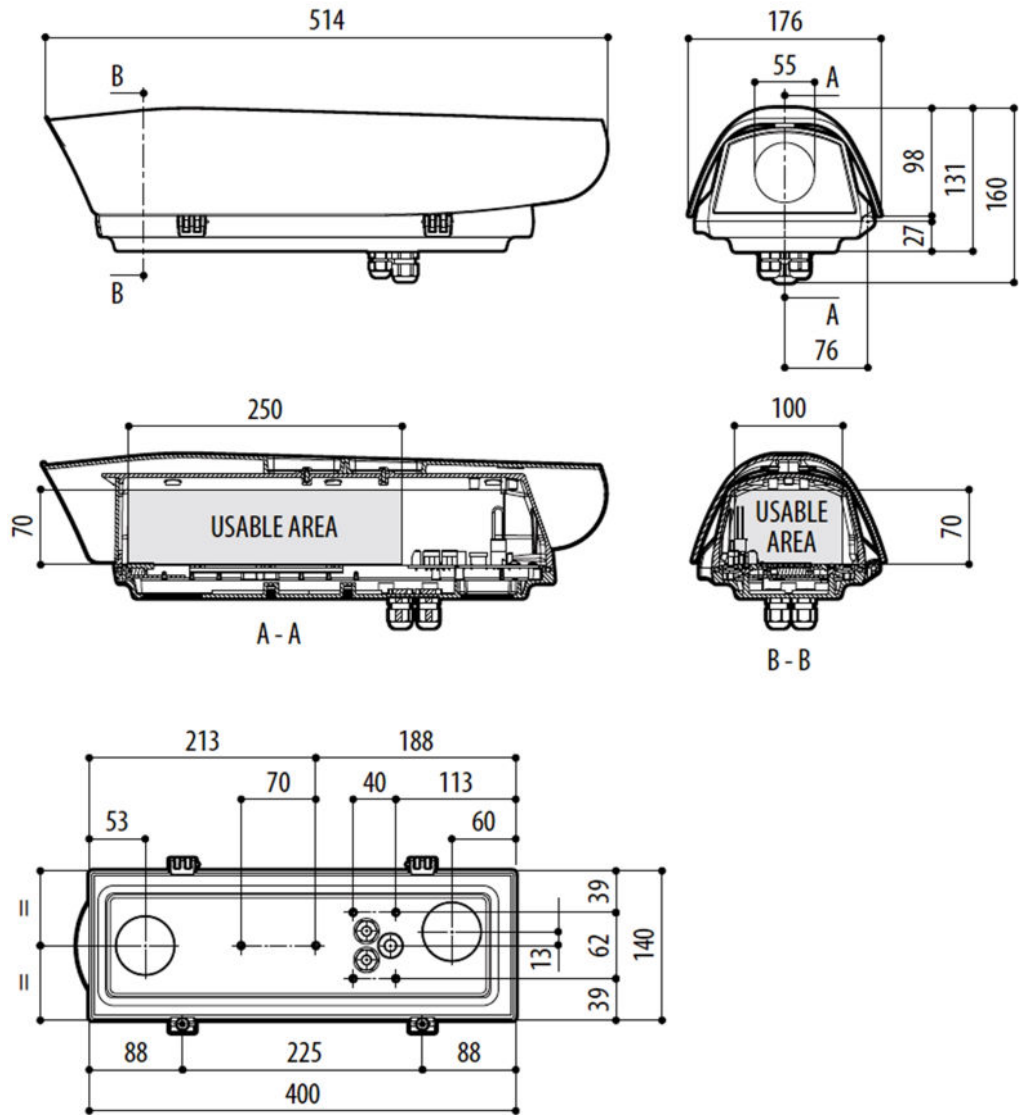

Fig.13

Index

A

About this manual.....	4
Accessories.....	14
Attaching the bracket.....	9

B

Blower.....	16
Blower installation.....	16
Board description.....	11

C

Camera power supply.....	15
Camera power supply installation.....	15
Certifications.....	22
Cleaning.....	18
Connection of the power supply line.....	12
Contents.....	8
Copyright and trademarks.....	4

D

Digital I/O.....	21
Disposal of waste materials.....	19
Disposing of packaging material.....	8

E

Electrical.....	21
Environment.....	22

G

General.....	20
--------------	----

H

Heater.....	14
Heater installation.....	14
Housing window.....	20
How to install the camera.....	10
How to open the housing.....	10

I

Identification.....	7
Installation.....	10
Installation of the version with double filter for air renewal.....	12

M

Mechanical.....	20
-----------------	----

P

Preparatory work before installation.....	9
Preparing the product for use.....	8
Product description and type designation.....	7
Product markings.....	7

S

Safety rules.....	5
-------------------	---

T

Technical data.....	20
Technical drawings.....	23
Type of cable.....	12
Typographical conventions.....	4

U

Unpacking.....	8
----------------	---

W

Window and plastic cover cleaning.....	18
--	----